

Quality
Endorsed
Company
ISO9002
LIC NO. 155
STANDARDS AUSTRALIA

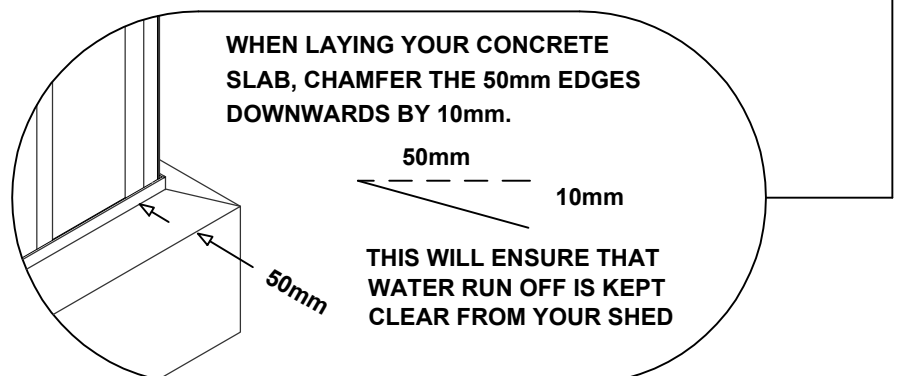

We thank you for choosing an Australian Made Shed. For further assistance please visit our detailed instructional video library at <http://www.absco.com.au/videos.php>

At ABSCO Industries we are always looking to be number ONE, so please let us know what you think of our instructions. Feedback makes us better.
feedback@absco.com.au.

GENERAL INSTRUCTIONS

- Before commencing any assembly, read through these instructions in detail to gain a thorough understanding of assembly methods and associated details.
- Unpack the carton and carefully identify and check off all the parts against the parts described and illustrated on pages three and four.

SITE PREPARATION

- The site for the shed must be level.
- It is recommended that the shed be set on a 100mm concrete slab and anchored down appropriately (refer page 15 for details).
- Anchor sets are not supplied as standard items with this product.

TOOLS REQUIRED



A NOTE ON SAFETY













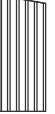

- Some parts may have sharp edges. It is advisable to wear gloves when handling these items and safety glasses if drilling holes. Sensible shoes are highly recommended.
- Do not erect your shed in windy conditions, ensure that the shed is securely anchored to a solid foundation immediately after construction is completed.
- It is highly recommended to erect the shed with two or more people.

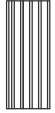

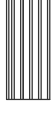
Absco Space Saver Shed

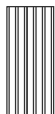
Model: 15081S







COMPONENTS PACKING LIST - CHECK OFF ALL COMPONENTS

QTY	COMPONENT DESCRIPTION	PART No.	CHECK	QTY	COMPONENT DESCRIPTION	PART No.	CHECK
2	 STEEL SHEET 1915 X 773mm	43B		1	 CHANNEL L = 1513mm	53C	
1	 STEEL SHEET 1915mm X 773mm	X4L		1	 CHANNEL L = 1513mm	81F	
1	 STEEL SHEET 1915mm X 773mm	X2R		2	 CHANNEL L = 1513mm	81E	
2	 STEEL SHEET 865mm X 773mm	43D		1	 CHANNEL L = 1785mm	80A	
1	 STEEL SHEET 1785mm X 711mm	34A		2	 CHANNEL L = 786mm	61B	
1	 STEEL SHEET 1725mm X 773mm	B		2	 CHANNEL L = 773mm	81J	
1	 CHANNEL L = 1513mm	53A		1	 CHANNEL L = 783mm	79C	
1	 CHANNEL L = 1513mm	53B					

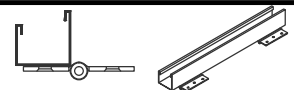
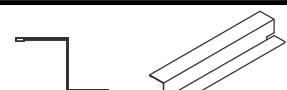
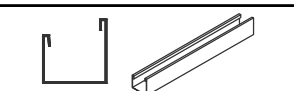
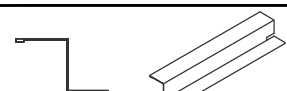
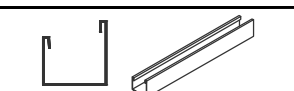
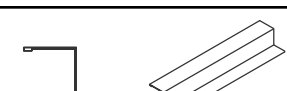
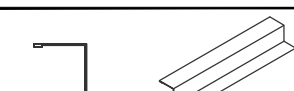
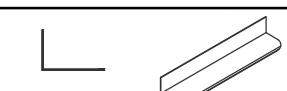
Absco Space Saver Shed

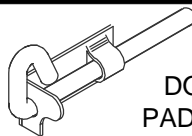
Model: 15081S

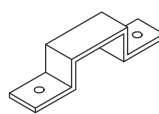
COMPONENTS PACKING LIST - (CONT.) CHECK OFF ALL COMPONENTS

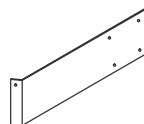
QTY	COMPONENT DESCRIPTION	PART No.	CHECK	QTY	COMPONENT DESCRIPTION	PART No.	CHECK
1	 CHANNEL WITH HINGES L = 1725mm	58A		1	 JAMB L= 1785mm	89B	
1	 CHANNEL L = 1725mm	58B		1	 JAMB L= 783mm	90C	
2	 CHANNEL L = 773mm	58C		2	 JAMB L= 1120mm	91A	
1	 JAMB L= 1785mm	89A		2	 LIP TRIM L= 865mm	88B	
CONTENTS OF FITTINGS PACKET							
120	 SELF TAPPING SCREWS (10mm)			1	 DOOR PADBOLT	22A	
6	 4mm CSK SCREW & NUT SECURE HINGES TO DOOR			1	DOOR PADBOLT HASP 		
1	ASSEMBLY INSTRUCTIONS			6	 3mm POP RIVETS SECURE HINGES TO DOOR (ALTERNATIVE FIXING METHOD)		
6	 SELF TAPPING SCREWS (20mm)			1	 DOOR STRAP L: 165mm	12A	

VIEW OF ROOF COMPONENTS

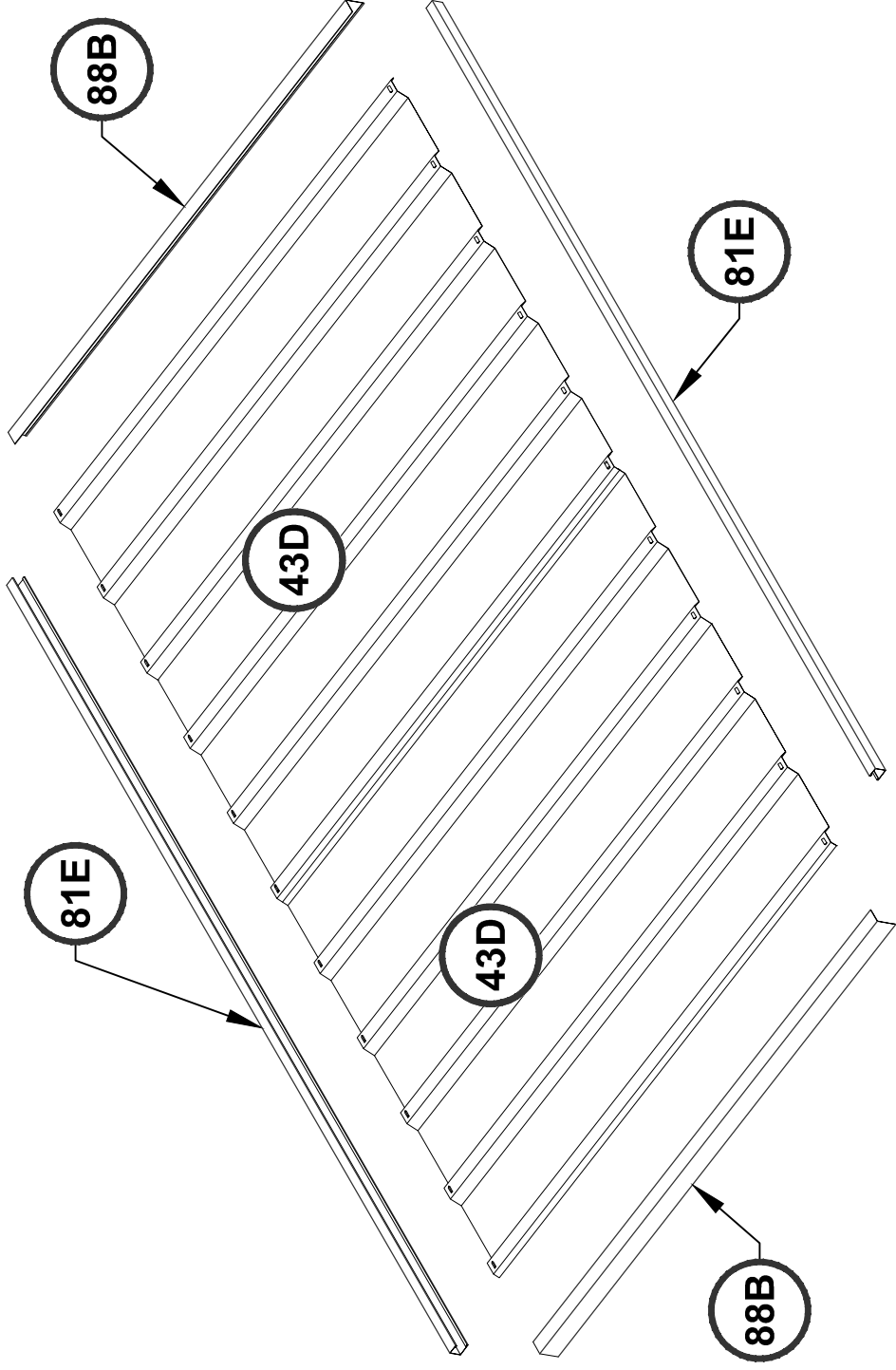

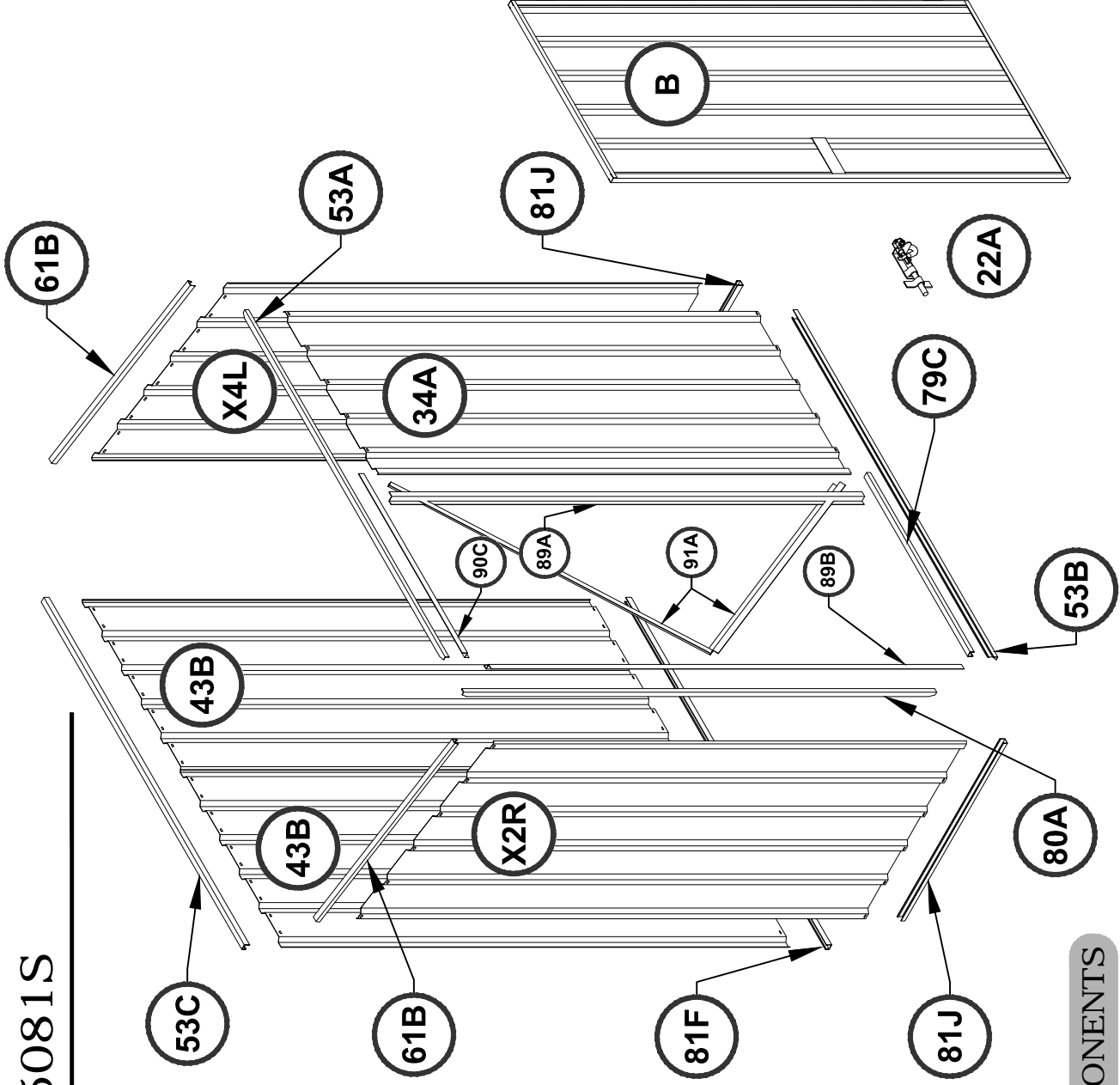

VIEW OF WALL COMPONENTS

ABSCO ASSEMBLY INTRODUCTION

The snap-tite assembly system locks all perimeter channels to all roof and wall sheets without the need for tools and fasteners.

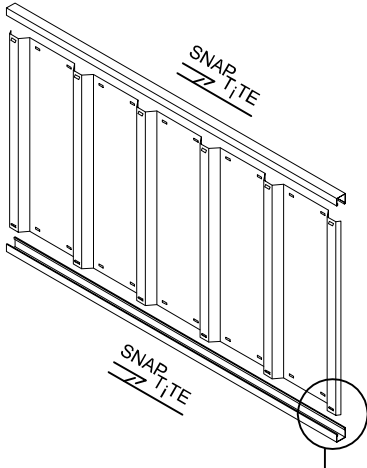

To pre-assemble the four wall panels and two roof panels, the perimeter channels are secured to the top and bottom of each panel using the snap-tite system, as detailed on the following pages wherever you see the symbol.

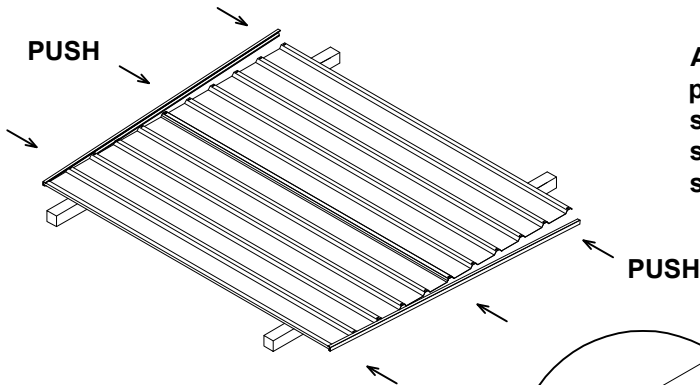
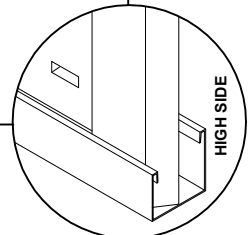
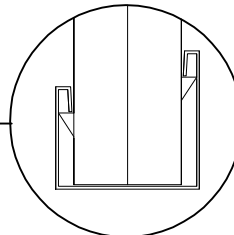
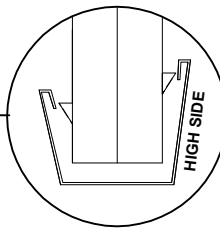
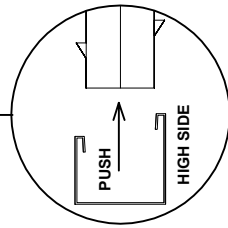
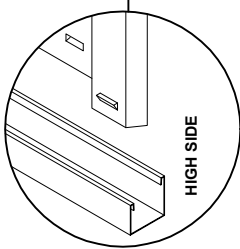
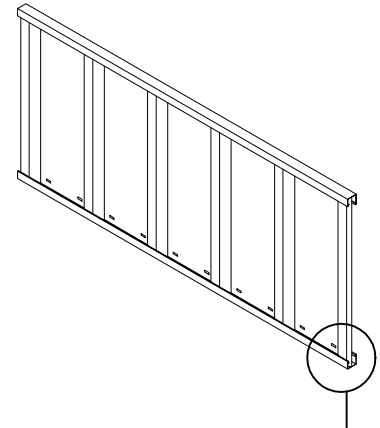

After joining sheets together, position channel over one end of the sheets, gently tapping it over the sheets, working along the sheets to the other end.

Position sheets on timbers, trestles or partly over edge of concrete slab.

Each perimeter channel must finish flush with the edges of the sheets. The snap-tite system allows adjustment for this process by simply tapping the channel along the sheets until each end is neatly flush.

FASTENING SYMBOLS



Join components together with one screw at this location only, as some channel sections have extra holes that are not required for this model of garden shed



3mm POP RIVETS



4mm NUT & BOLT SET



Do not join components together at this location yet, as the screw may obstruct further assembly of other components

DOOR PANEL ASSEMBLY

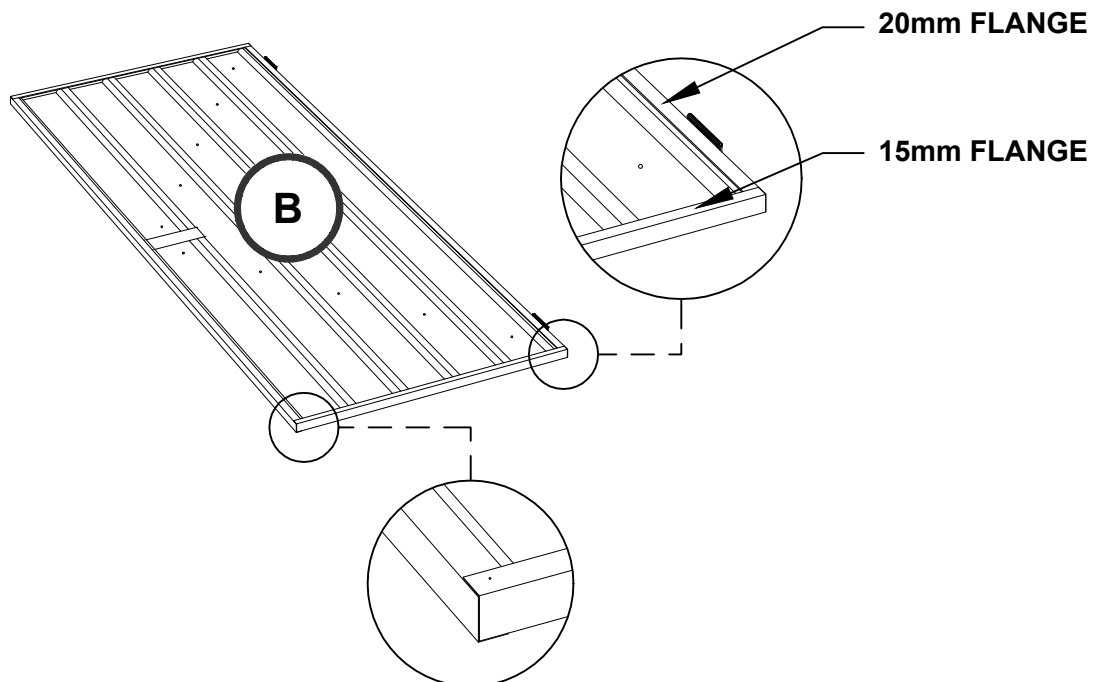
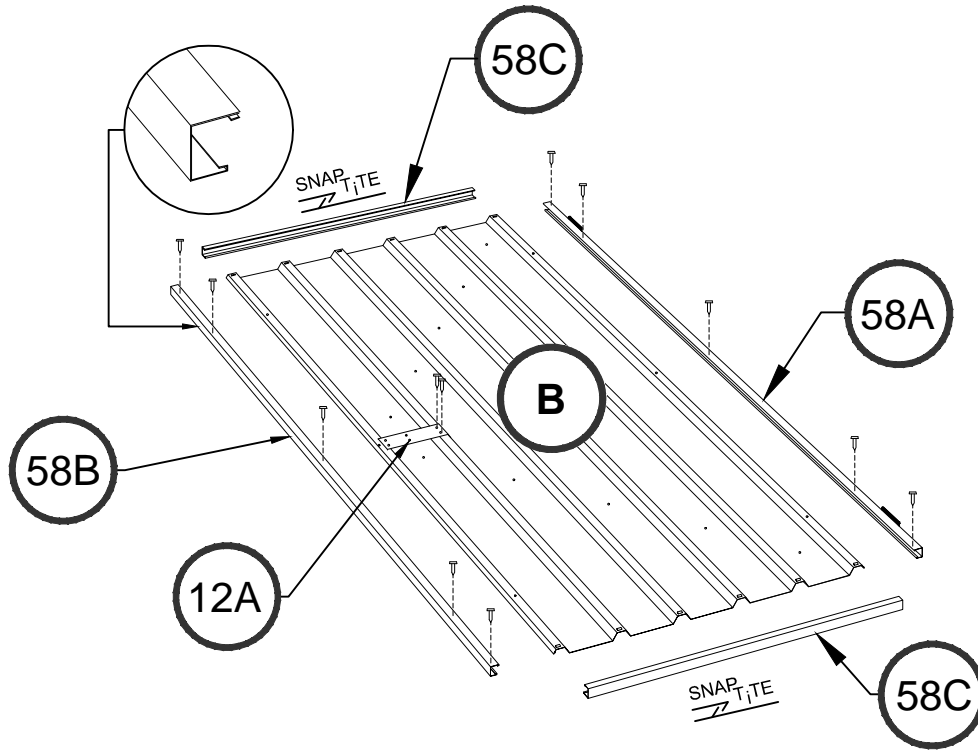

REAR PANEL ASSEMBLY

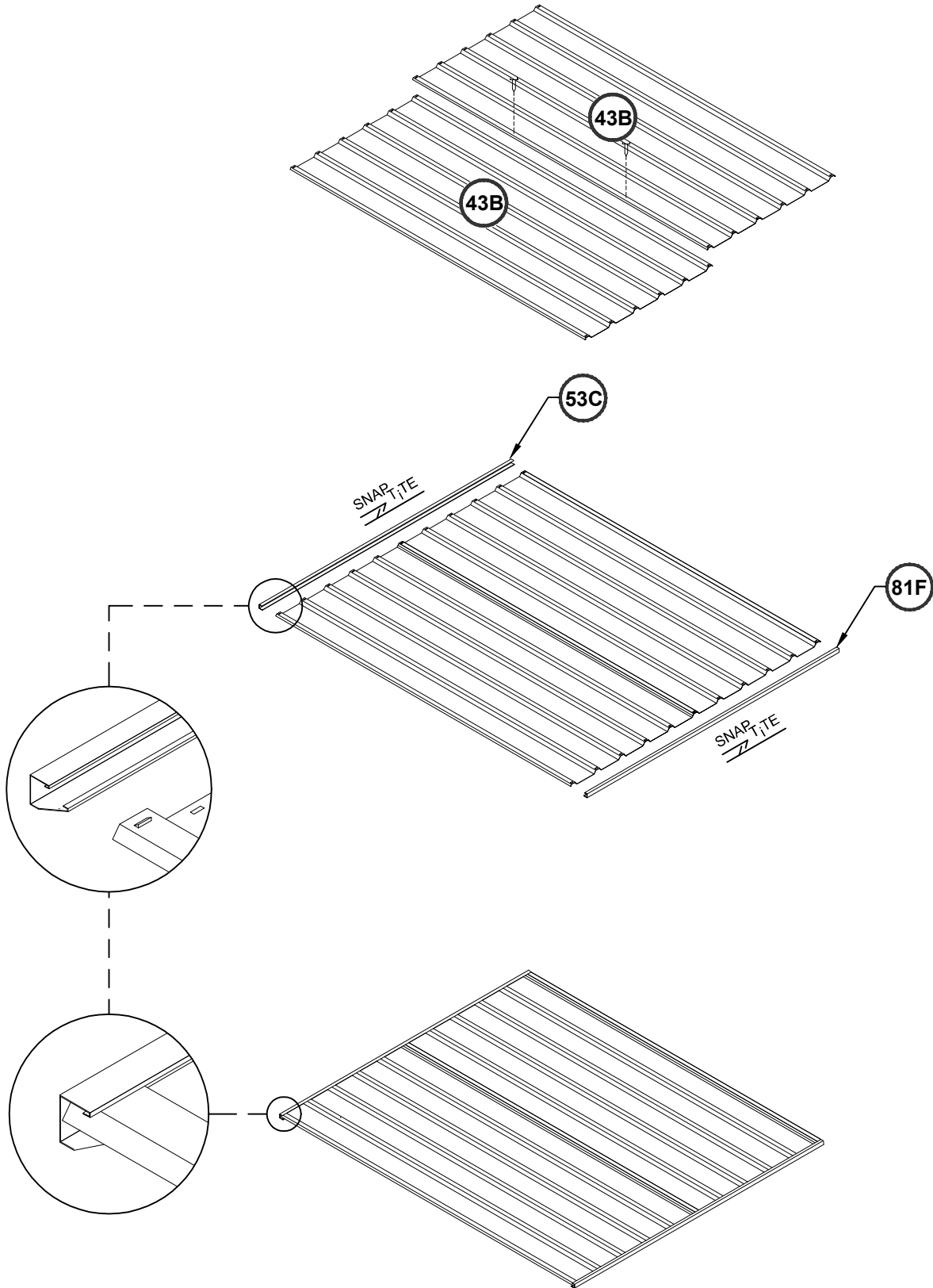

SIDE PANEL ASSEMBLY

(TWO REQUIRED)

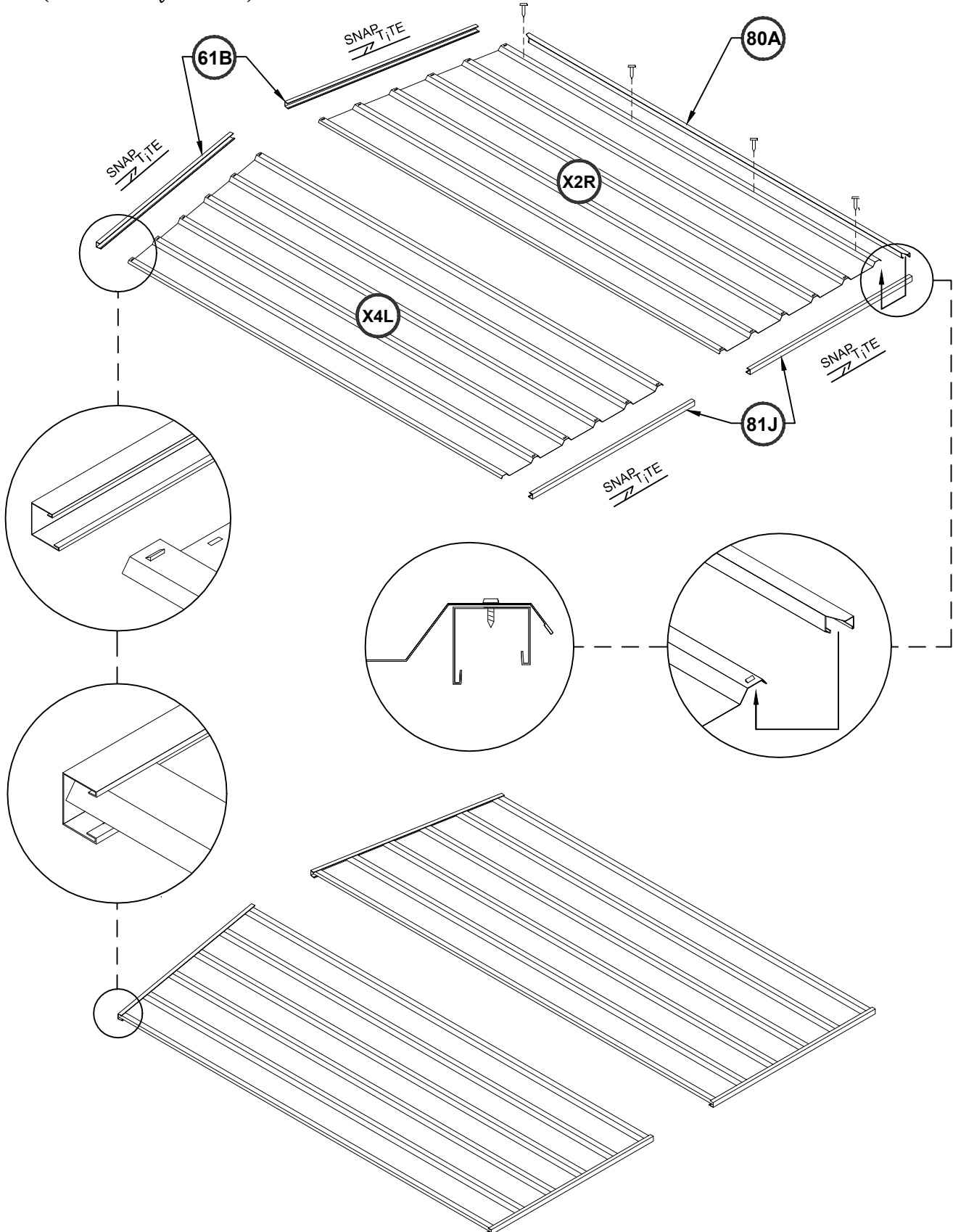

ROOF ASSEMBLY

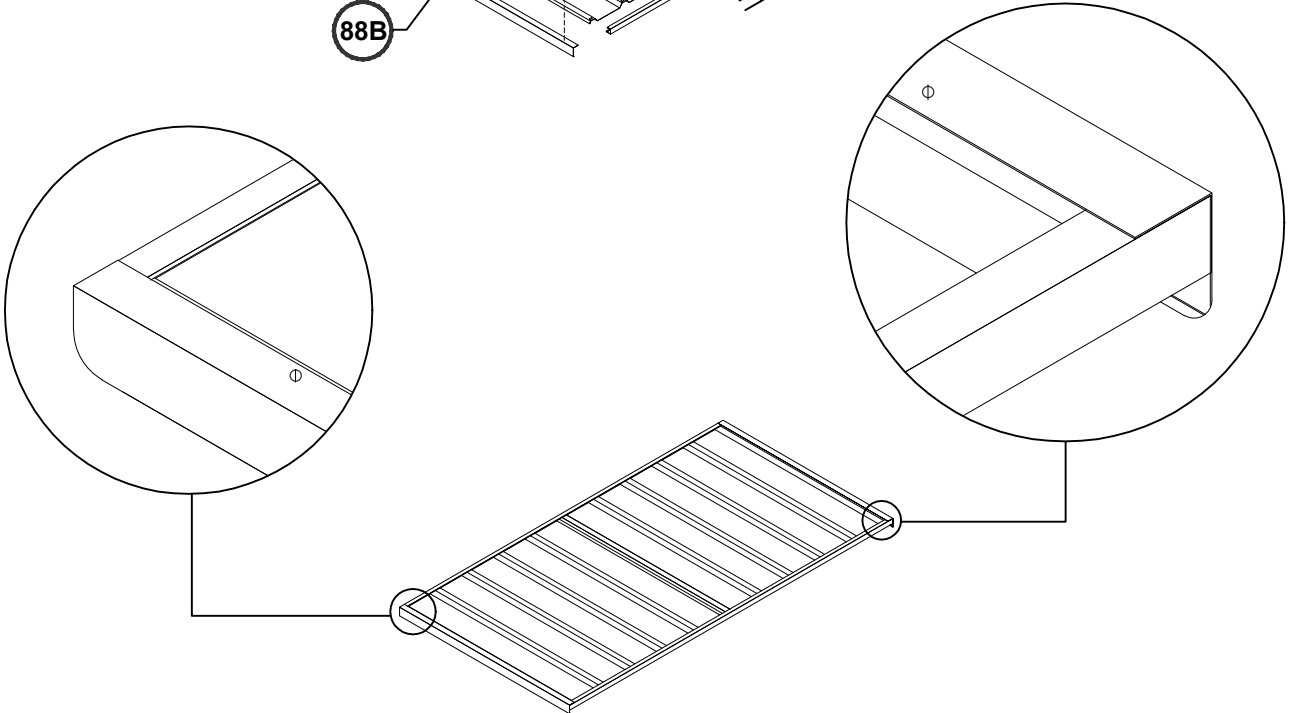
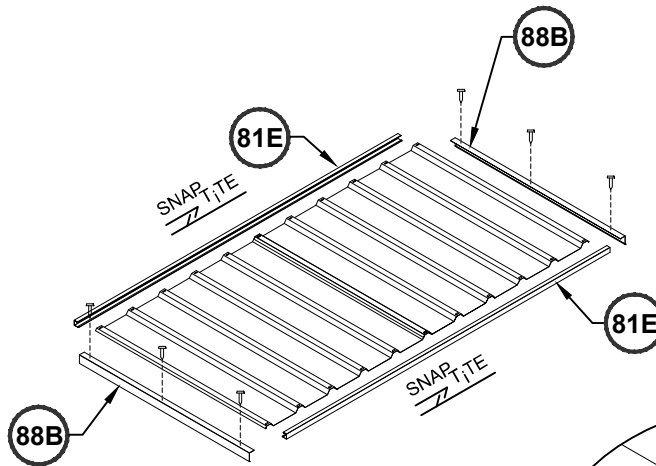
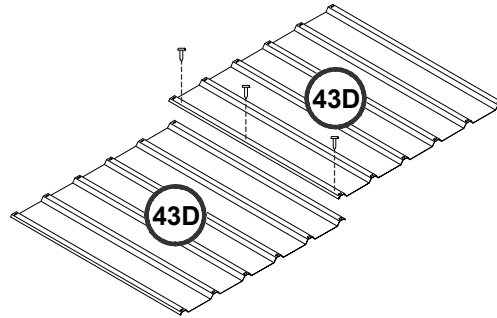

FRONT PANEL ASSEMBLY

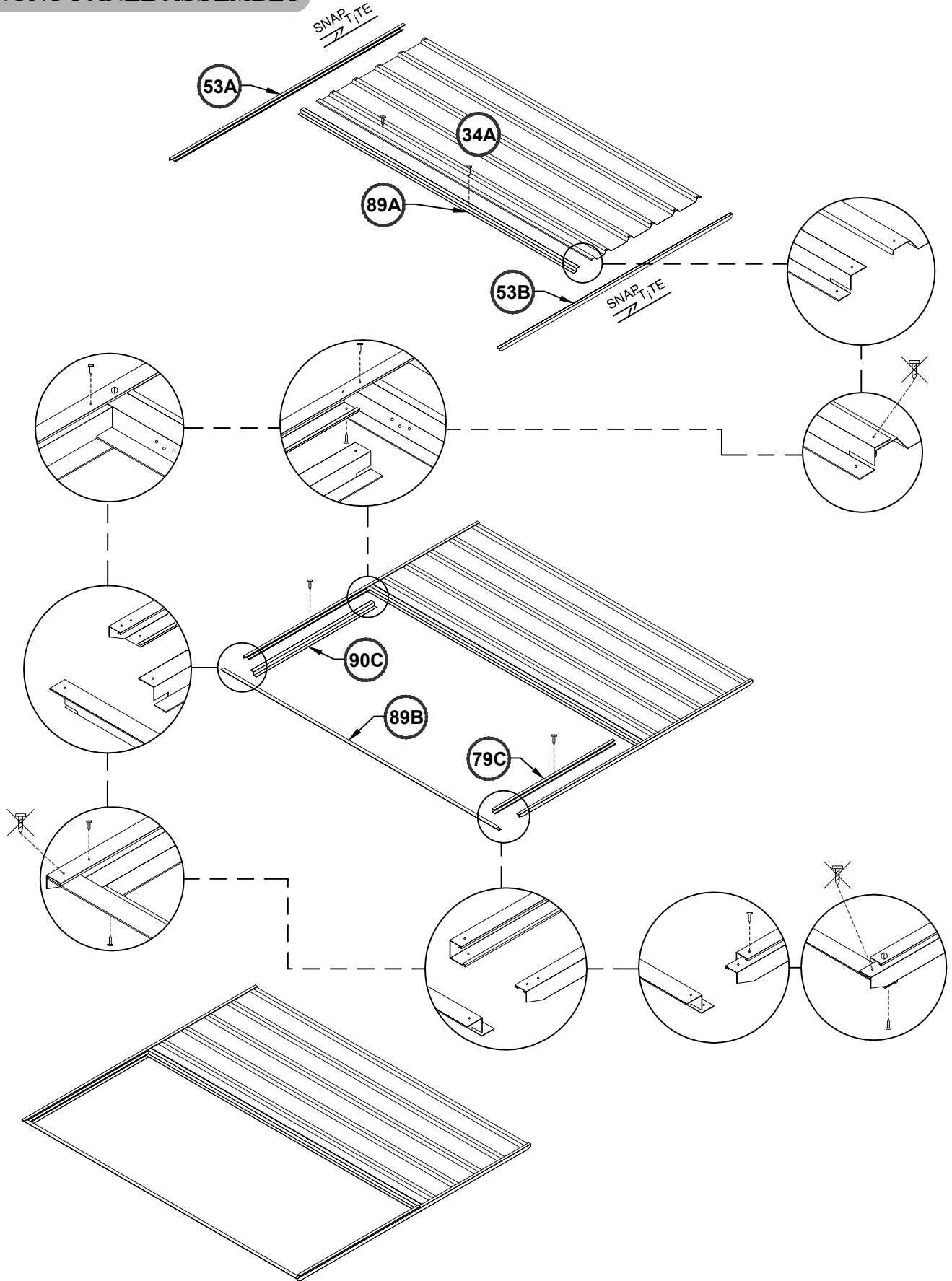

DOOR PANEL ASSEMBLY

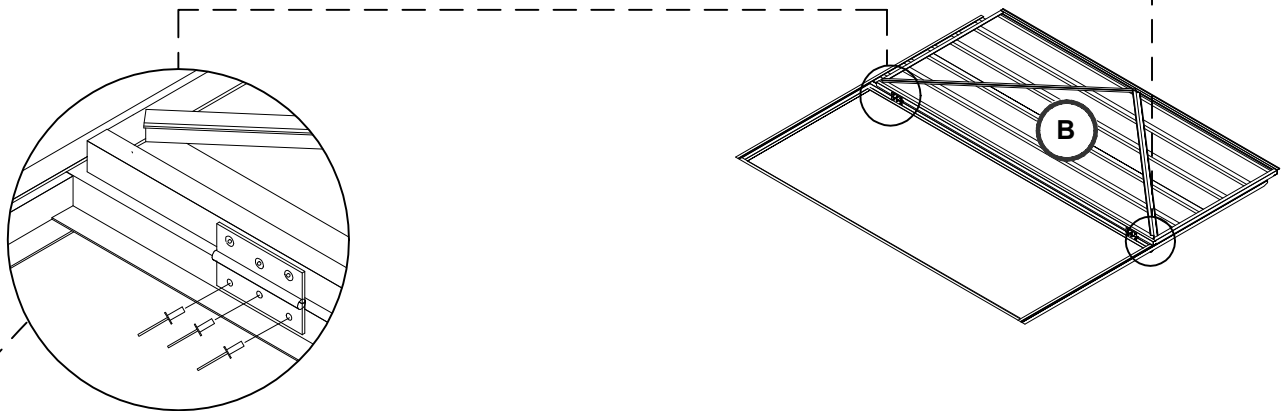
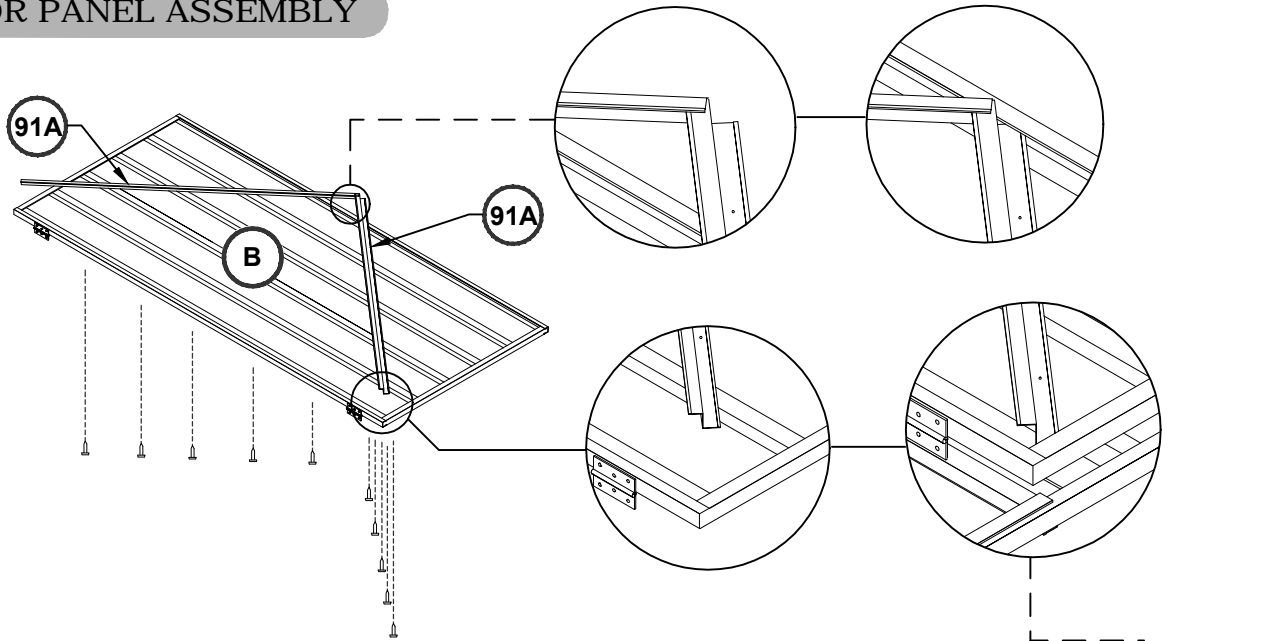

NOTE: NUTS AND BOLTS (SUPPLIED) MAY BE USED INSTEAD OF POP RIVETS (SUPPLIED) BY SIMPLY ENLARGING THE HINGE HOLE SETS IN THE JAMB USING A 4MM DRILL BIT

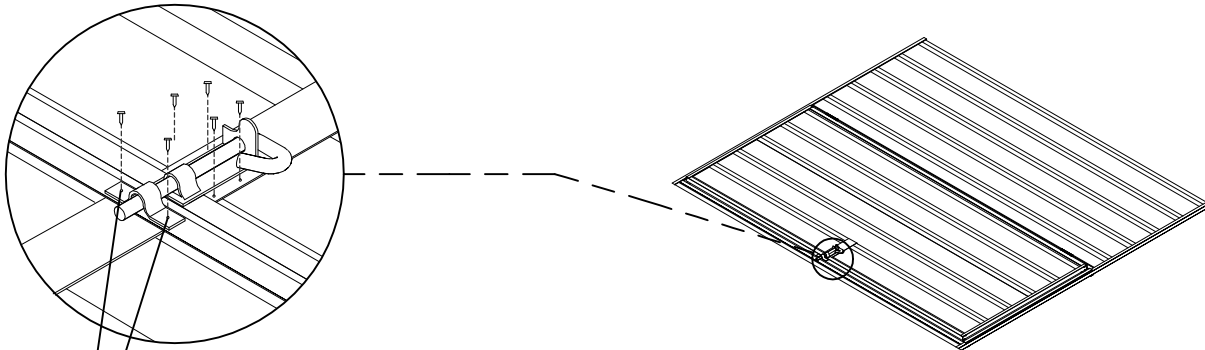

NOTE: The two holes required to connect the padbolt hasp for each door have not been pre-punched, to allow for proper alignment. position each hasp centrally over the padbolt shaft, and drill 3mm holes and secure with screws

PANEL CONSTRUCTION

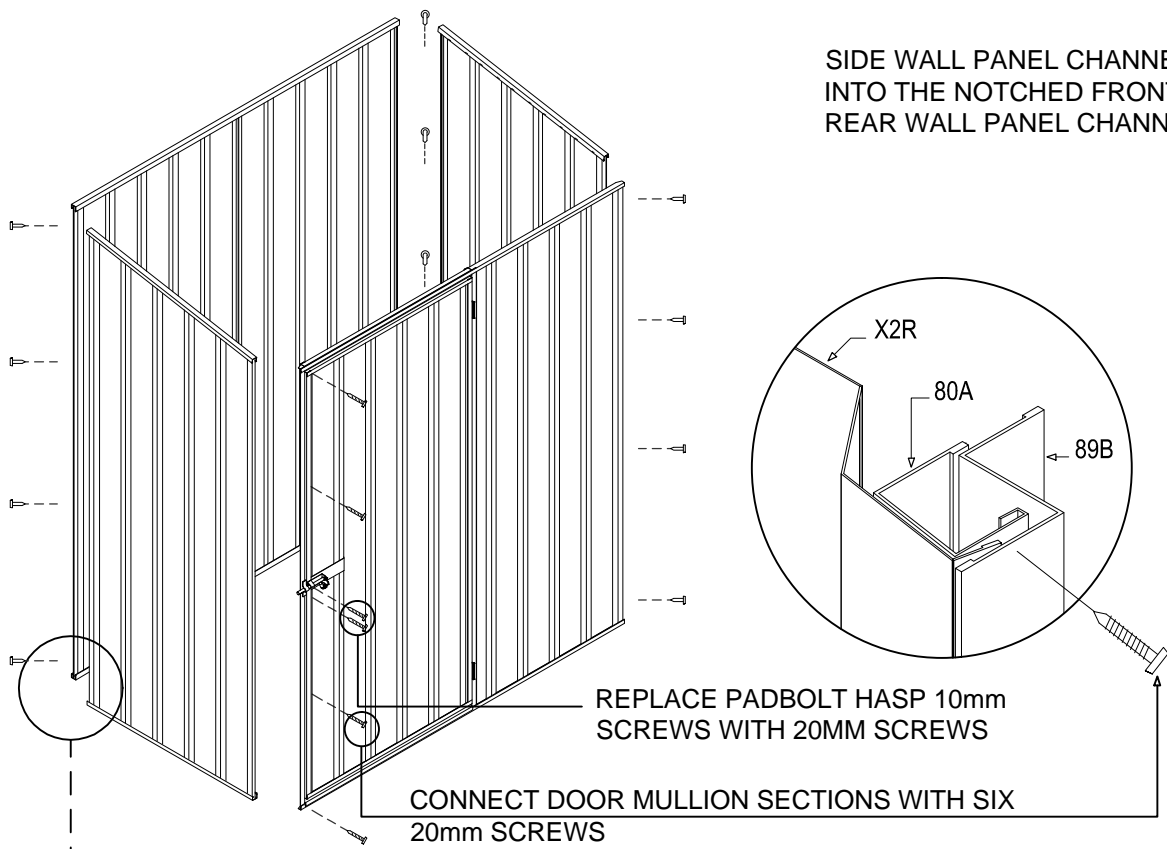

FINAL CONSTRUCTION

ANCHORING OF SHED

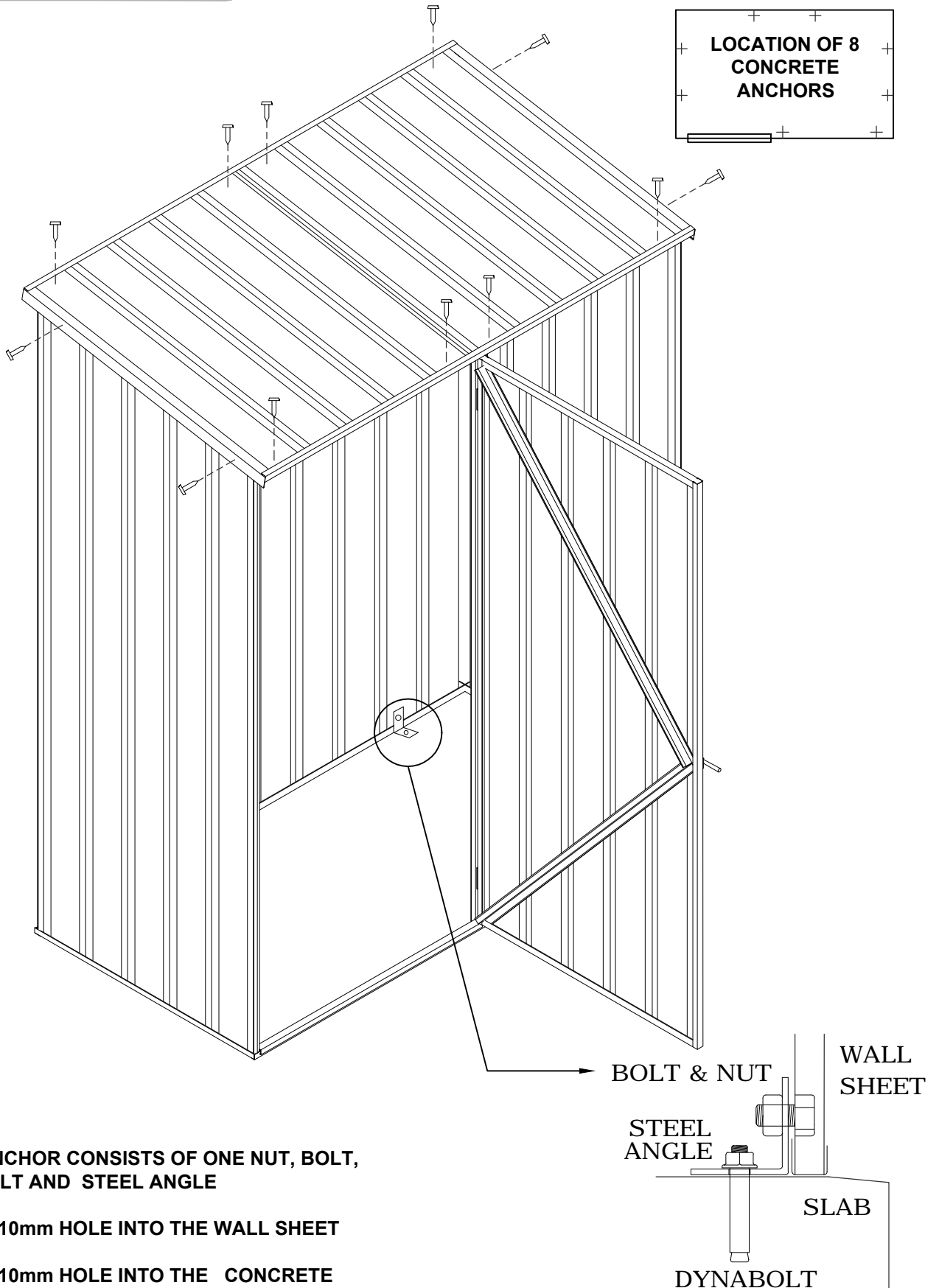

- EACH ANCHOR CONSISTS OF ONE NUT, BOLT, DYNABOLT AND STEEL ANGLE
- DRILL A 10mm HOLE INTO THE WALL SHEET
- DRILL A 10mm HOLE INTO THE CONCRETE